



# SHURFLO® MAXI WATER BOOST SYSTEM

MAINTAINS CONSISTENT WATER PRESSURE FOR FOUNTAIN SYSTEMS

Maxi Water Boost:  
804-026 115 VAC 1/2" (13 mm) Barb Fittings  
804-037 115 VAC 3/8" (10 mm) Barb Fittings  
Replacement Bladder: 94-697-00



## APPLICATIONS

Fountain  
Coffee  
Drinking water

## FEATURES • BENEFITS

Increases flow and pressure to carbonated and non-carbonated soda valves for consistent drink quality  
Maximizes filter life on filtration systems  
Replaceable bladder for maximum system life and simple maintenance  
Self-priming pump can run dry without damage  
Eliminates pulsation at dispenser valve resulting in more accurate brix ratio and maximum syrup utilization

Low profile allows for undercounter installation  
Rigid stainless steel tanks  
Complete turn-key package  
Replaceable bladder  
Quick connects  
NSF® Certified

## INSTALLATION TIPS

Must be installed BEFORE the water filtration

Charge tank precharge at time of installation is at 50 psi (3.4 bar)

Check precharge each service visit to ensure optimum performance

Do not charge accumulator tank with CO<sub>2</sub>

Use NSF listed high pressure braided tubing for inlet/outlet port (not included)

## OPERATION TIPS

## SIZING

Max. Working Pressure: 117 psi (8 bar).

Ports: 804-026 - 1/2" (13 mm) barb  
804-037 - 3/8" (10 mm) barb inlet/outlet

# SHURFLO® MAXI WATER BOOST SYSTEM

804-026 • 804-037

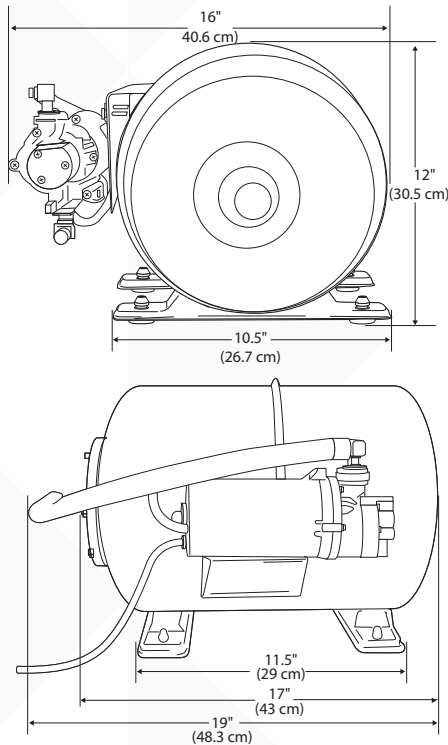

## SPECIFICATIONS

### Booster Pump

SHURflo 90 psi 115 VAC 8000 series corded pump (NSF, UL, CUL listed)

### Accumulator Tank

6 gallon (22.7 L) SS and butyl rubber bladder (NSF listed)

### Ports

804-026: 1/2" (13 mm) barb

804-037: 3/8" (10 mm) barb inlet/outlet

### Pre-charge

W/air at installation.

50 psi (3.4 bar) (recommended for most beverage applications)

### Draw Down Volume

3.1 gallons @ 50 psi (11.7 L @ 3.4 bar)

### Dimensions

12" H x 19" W x 16" D (30.5 x 48.3 x 40.6 cm)

### Electrical

115 Vac

### Max. Working Pressure

117 psi (8 bar)

### Temperature Limits

34 - 120°F (1.1 - 4.9°C)

### Weight

18 pounds (8.1 kg) (empty)

## WARRANTY

Limited Pentair® Warranty is valid from the date of manufacture or with proof of purchase:

2088 - One year  
 Water Boost - One year  
 Water Pressure Reducer Valve - One year  
 8000, 8025, 8010, 8075, 8095 - One year

Pentair will provide a copy of the warranty upon request.



## FILTRATION & PROCESSING SOLUTIONS

EVERPURE-SHURFLO WORLD HEADQUARTERS, 1040 MUIRFIELD DRIVE, HANOVER PARK, IL 60133 USA • WWW.EVERPURE.COM  
 800.942.1153 MAIN (US ONLY) • 630.307.3000 MAIN • 630.307.3030 FAX • CSEVERPURE@PENTAIR.COM EMAIL

EVERPURE-SHURFLO AUSTRALIA / NEW ZEALAND, 1-21 MONASH DRIVE, DANDENONG SOUTH, VIC, 3175, AUSTRALIA  
 1300.576.190 TEL • AU.EVERPURE@PENTAIR.COM EMAIL

EVERPURE-SHURFLO CHINA, 21F CLOUD 9 PLAZA, NO 1118, SHANGHAI, 200052, CHINA  
 86.21.3211.4588 TEL • 86.21.3211.4580 FAX • CHINA.WATER@PENTAIR.COM EMAIL

EVERPURE-SHURFLO INDIA, GREEN BOULEVARD, B-9/A, 7TH FLOOR - TOWER B SECTOR 62, NOIDA - 201301  
 91.120.419.9444 TEL • 91.120.419.9400 FAX • INDIACUSTOMER@PENTAIR.COM EMAIL

EVERPURE-SHURFLO EUROPE, PENTAIR WATER BELGIUM BVBA, INDUSTRIEPARK WOLFSTEE, TOEKOMSTLAAN, 30 B-2200 HERENTALS, BELGIUM  
 +32.(0).14.283.500 TEL • +32.(0).14.283.505 FAX • SALES@EVERPURE-EUROPE.COM EMAIL

EVERPURE-SHURFLO JAPAN INC., HASHIMOTO MN BLDG. 7F, 3-25-1 HASHIMOTO, MIDORI-KU, SAGAMIHARA-SHI KANAGAWA 252-0143, JAPAN  
 81.(0)42.775.3011 TEL • 81.(0)42.775.3015 FAX • INFO@EVERPURE.CO.JP EMAIL

EVERPURE-SHURFLO SOUTHEAST ASIA, 390 HAVELOCK ROAD, #04-01, KING'S CENTRE, SINGAPORE 169662  
 65.6795.2213 TEL • FAX: 65.6795.2219 FAX • CSEVERPURE@PENTAIR.COM EMAIL

All Pentair trademarks and logos are owned by Pentair, Inc. All other brand or product names are trademarks or registered marks of their respective owners. Because we are continuously improving our products and services, Pentair reserves the right to change specifications without prior notice. Pentair is an equal opportunity employer.