



AURORA[®]

MODEL 382
VERTICAL INLINE
CENTRIFUGAL PUMP
INSTRUCTION AND REPAIR MANUAL

NOTE! To the installer: Please make sure you provide this manual to the owner of the equipment or to the responsible party who maintains the system.

THIS PAGE INTENTIONALLY LEFT BLANK

CALIFORNIA PROPOSITION 65 WARNING:

▲ WARNING This product and related accessories contain chemicals known to the State of California to cause cancer, birth defects or other reproductive harm.

SERVICE

Your Aurora pump requires no maintenance other than periodic inspection and occasional cleaning. The intent of inspection is to prevent breakdown, thus obtaining optimum service life. The pump is lubricated by the liquid being pumped and therefore does not require periodic lubrication. The motor, however may require lubrication, in which case, the motor manufacturer's recommendation should be followed.

REPAIRS

The pump may be disassembled using the illustrations and text provided. Although complete disassembly is covered, it will seldom be necessary to completely disassemble your Aurora pump.

The illustrations accompanying the disassembly instructions show the pump at various stages of disassembly. The illustrations are intended to aid in the correct identification of the parts mentioned in the text.

Inspect removed parts at disassembly to determine their reusability. Cracked castings should never be reused. Gaskets should be replaced at reassembly simply as a matter of economy; they are much less expensive to replace routinely than to replace as the

need occurs. In general it is economical to return to the manufacturer for repair only the motor and motor controller.

DISASSEMBLY

Disassemble only what is needed to make repairs or to accomplish inspection. Proceed to disassemble the pump as follows: (See Figure 2).

1. Break electrical connections to prevent any possibility of pump starting during disassembly.
2. Remove plugs (4) from casing (6) to drain pump.
3. Remove all relief, cooling, flushing, or drain lines from the pump, including compression connections (1 and 2) and tubing (3). Break suction and discharge connections only if it is desired to remove casing (6).

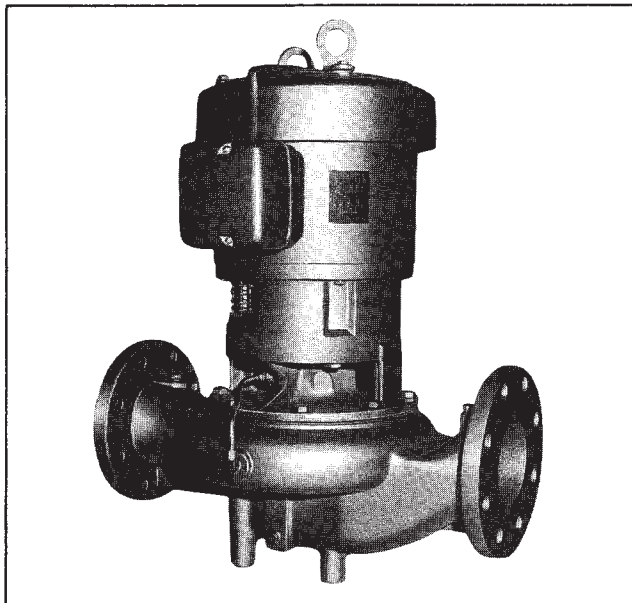

A. Assembled unit.

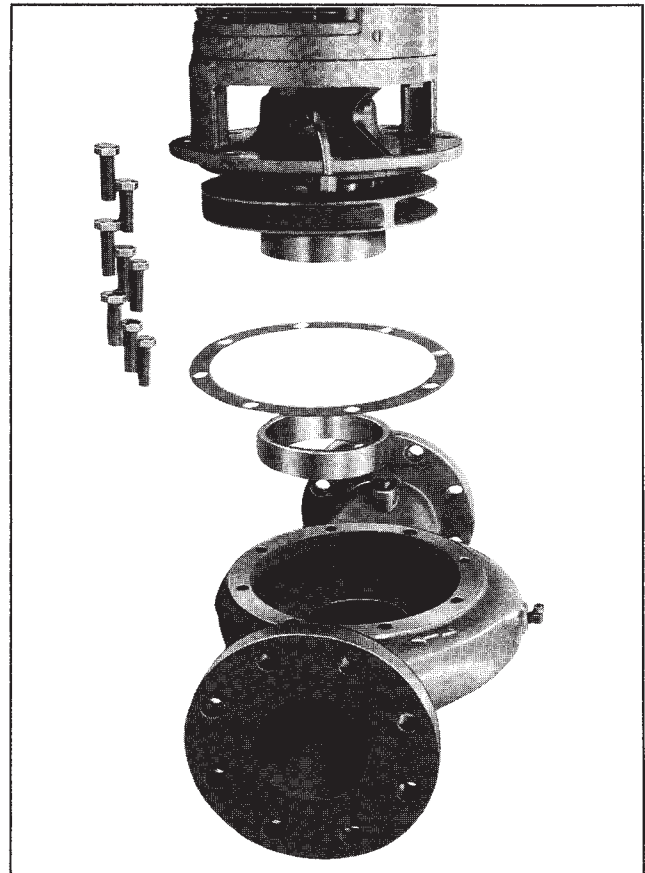

B. Casing, gasket and wearing ring removed.

4. Remove capscrews (5) and lift pump assembly from casing (6). Remove gasket (8).

5. Unscrew impeller screw (9) and remove washer (9A) taking care not to damage gasket (9B).

6. Slide impeller (11) and impeller key (12) from shaft, again taking care not to damage gasket (10) located behind the impeller. Remove gasket (10).

7. Wearing ring(s) (7 & 16) are pressed into their housings with an interference fit, and must be removed with a puller. New ring(s) should be used for reassembly, since it is likely that during removal this fit will be lost.

8. Impeller wear rings (optional - 14 and 15) are pressed on and must be cut off if replacement is necessary. If they are turned off on a lathe, take care not to cut into the impeller.

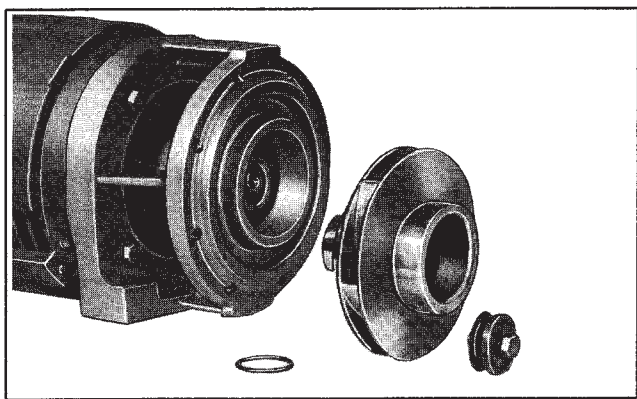

C. Impeller, O ring removed.

9. Slide sleeve (25) with rotating parts of mechanical seal (27) from the shaft. The sleeve should be carefully cleaned to remove any residue that may be remaining in the seal area. The rubber in the seal (27) may have become partially adhered to the sleeve. The sleeve must also be checked for abrasion or corrosion that can occur when fluid residue penetrates between the seal (27) and the sleeve (25). The sleeve under the seal may be polished lightly to a 32RMS finish before reassembly. Do not reuse a pitted sleeve. Pin (61) may be removed if necessary.

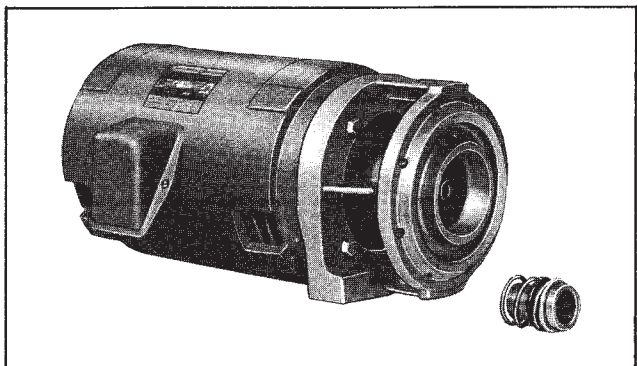

D. Mechanical seal removed.

CAUTION

The mechanical seal (see Figure 1) is a precision product and must be treated as such. During removal, great care must be taken to avoid dropping any part of the seal. Take particular care not to scratch the lapped faces on the washer or the sealing seat. Do not put a seal back into service until the sealing faces of the washer and seat have been lapped or replaced.

10. Unscrew capscrews (32) and remove bracket (35) from the motor.

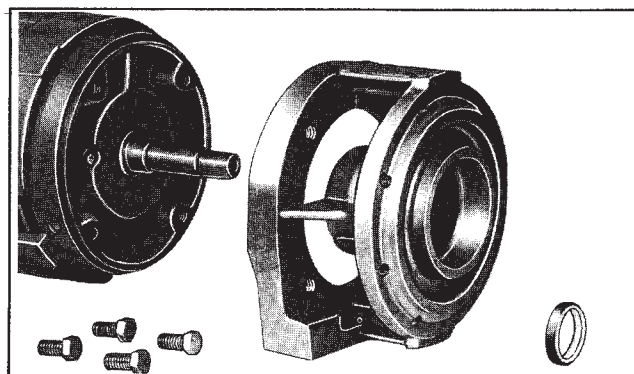

E. Bracket, seal flexible cup and stationary seat removed.

11. The seal flexible cup and stationary seat should be pressed out of the bracket and the cavity cleaned of all residue. Make sure that the 1/32 inch radius in the seal seat cavity is not damaged during disassembly since a sharp edge can easily cut the flexible cup during reassembly.

12. Remove nameplate (34) and screws (33) only if replacement is needed.

REASSEMBLY

Reassembly will generally be in reverse order of disassembly. If disassembly was not complete, use only those steps related to your particular repair program.

1. The mechanical seal (27) (see Figure 1) cannot be installed as an assembly. It is necessary to have the seal seat properly in place before the balance of parts can be added. Thoroughly inspect the seal cavity in the bracket for burrs or nicks which could damage the seat of the seal. Apply a film of soap paste or flax soap (do not use oil or grease) to the seal seat and install, taking care to seat it evenly and squarely.

NOTE

If it is not possible to insert seat with fingers, place cardboard protecting ring furnished with seal over lapped face of seat and press into place with a piece of tubing having end cut square. The tubing should be slightly larger than the diameter of the shaft. Remove cardboard after seat is firmly in place.

2. Position bracket (35) on the motor and secure with capscrews (32). Tighten screws evenly to assure proper alignment.

3. If nameplate (34) was removed, install and attach with screws(33).

4. Wipe the sealing faces of the seat and seal washer clean. Oil these surfaces with a clean light oil. Lightly oil the shaft sleeve (25). Slide the entire rotating assembly onto the sleeve. The shaft sleeve with the seal rotating assembly on it may now be replaced on the motor shaft. Spring tension will probably prevent the sleeve from remaining in position axially until the impeller is locked against it.

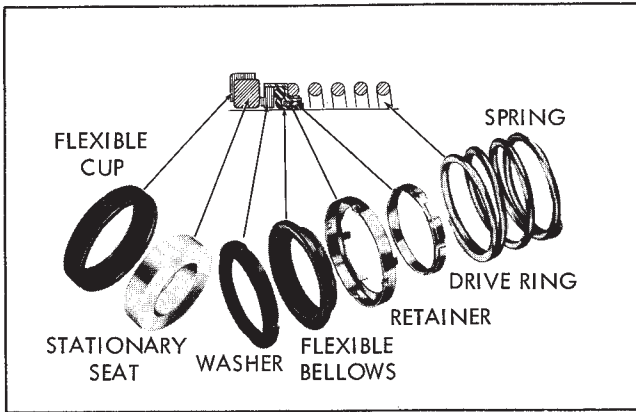

Figure 1. Mechanical Seal

5. Press wearing ring(s) (7 & 16) in casing (6) and bracket (35). Rings should not be hammered into place. Use a press, or clamp the parts in a bench vise, using wooden blocks to protect the rings. It may be necessary to pin or dowel the rings after assembly if the insert or casing has had rings replaced before, since each reassembly can stretch or tear metal and thereby loosen the fits. If the facilities are available, it is good practice to take a very light finish cut or to ream the inside diameter of the casing rings after pressing to restore round-

ness. When rings are pressed, they may get squeezed out of shape.

6. Place impeller wearing rings (optional - 14 and 15) on impeller (11), using the same care as for the case wearing rings. If the rings are to be trued on a lathe, do not clamp the impeller so tightly that it is permanently distorted.

7. Carefully place gasket (10) on motor end of impeller. Assemble key (12) and impeller (11) to motor shaft. Secure impeller with gasket (9B), washer (9A), and impeller screw (9).

8. Install the four pipe plugs (4) in the pump casing. Position the gasket (8) and casing (6) against the motor bracket and secure with screws (5).

10. Replace all relief, cooling, flushings, or drain lines from the pump including compression connections (1 and 2) and tubing (3). Connect discharge piping and suction piping if required, make sure to install gaskets on the flanged connections. Connect electricity to motor.

11. Read starting instructions before attempting to start pump.

STARTING PUMP AFTER REASSEMBLY

Do not start pump until all air and vapor has been bled and until making sure that there is liquid in the pump to provide the necessary lubrication. Without the fluid around it, the seal may be ruined in a few seconds of operation. It is possible that the mechanical seal may drip during the first few minutes to one hour of operation.

NOTE

WHEN ORDERING SPARE PARTS ALWAYS INCLUDE THE PUMP TYPE, SIZE, SERIAL NUMBER, AND THE PIECE NUMBER FROM THE THE EXPLODED VIEW IN THIS MANUAL.

ORDER ALL PARTS FROM YOUR LOCAL AUTHORIZED DISTRIBUTOR, FACTORY BRANCH SALES OFFICE OR THE FACTORY AT NORTH AURORA, ILLINOIS.

MODELS 382 LIST OF PARTS

1. Elbow	7. Wear Ring	11. Impeller	27. Seal
2. Connector	8. Gasket	12. Impeller Key	32. Capscrew
3. Tubing	9. Impeller Screw	14. Wear Ring	33. Screw
4. Plug, Pipe	9A. Washer	15. Wear Ring	34. Nameplate
5. Capscrew	9B. Gasket	16. Wear Ring	35. Bracket
6. Casing	10. Gasket	25. Sleeve	61. Pin

- NOTES: 1. BRONZE FITTED CONSTRUCTION WILL BE FURNISHED AS STANDARD UNLESS SPECIFIED.
 2. REFER TO FACTORY FOR SPECIAL ALLOYS.
 3. AURORA PUMP RESERVES THE RIGHT TO SUBSTITUTE MATERIALS WITHOUT NOTICE.
 4. PIECE NUMBERS 14 AND 15 ARE NOT FURNISHED AS STANDARD. WHEN FURNISHED IMPELLER MUST BE MODIFIED.

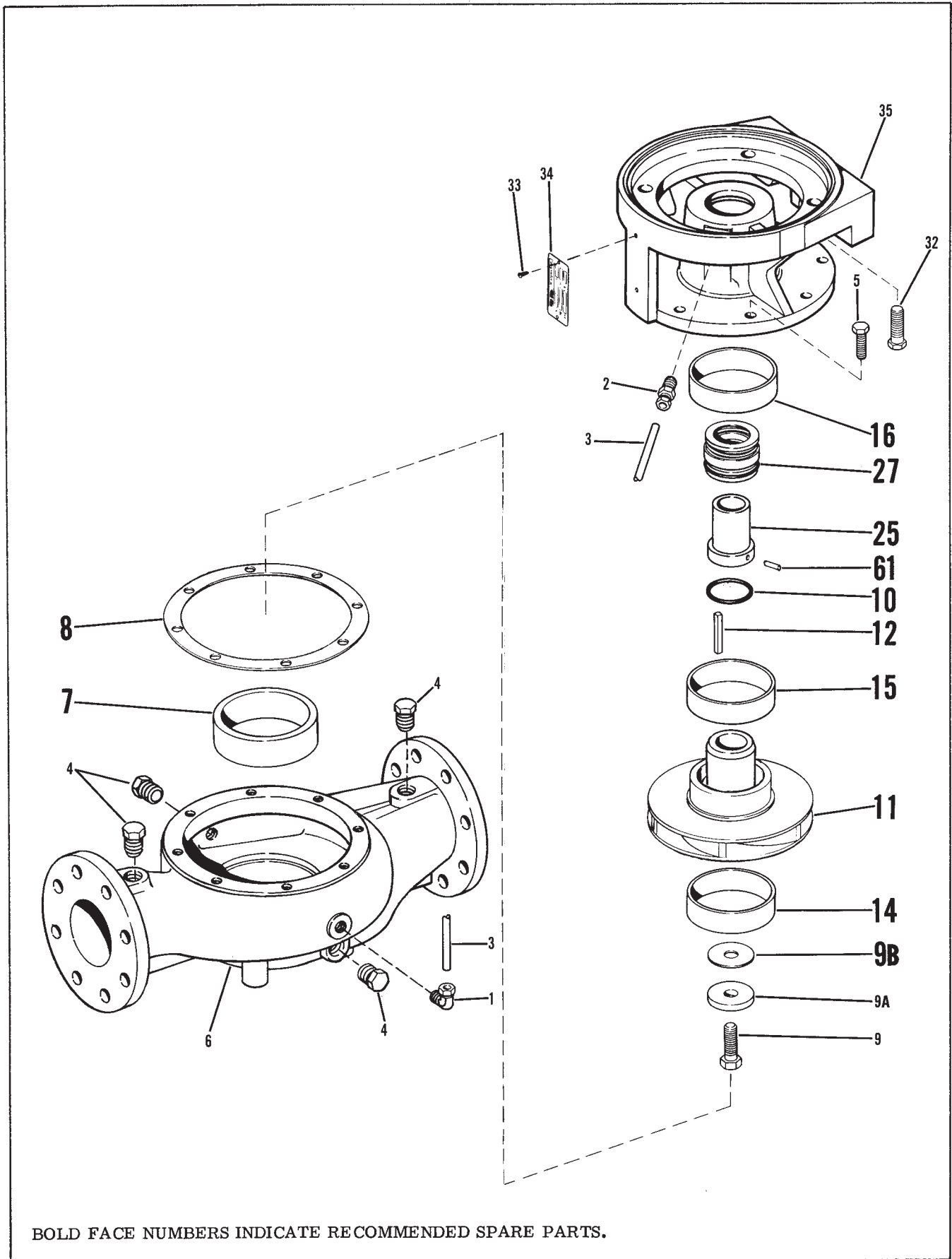

Figure 2. Exploded View

THIS PAGE INTENTIONALLY LEFT BLANK

WARRANTY

Seller warrants equipment (and its component parts) of its own manufacture against defects in materials and workmanship under normal use and service for one (1) year from the date of installation or start-up, or for eighteen (18) months after the date of shipment, whichever occurs first. Seller does not warrant accessories or components that are not manufactured by Seller; however, to the extent possible, Seller agrees to assign to Buyer its rights under the original manufacturer's warranty, without recourse to Seller. Buyer must give Seller notice in writing of any alleged defect covered by this warranty (together with all identifying details, including the serial number, the type of equipment, and the date of purchase) within thirty (30) days of the discovery of such defect during the warranty period. No claim made more than 30 days after the expiration of the warranty period shall be valid. Guarantees of performance and warranties are based on the use of original equipment manufactured (OEM) replacement parts. Seller assumes no responsibility or liability if alterations, non-authorized design modifications and/or non-OEM replacement parts are incorporated. If requested by Seller, any equipment (or its component parts) must be promptly returned to Seller prior to any attempted repair, or sent to an authorized service station designated by Seller, and Buyer shall prepay all shipping expenses. Seller shall not be liable for any loss or damage to goods in transit, nor will any warranty claim be valid unless the returned goods are received intact and undamaged as a result of shipment. Repaired or replaced material returned to customer will be shipped F.O.B., Seller's factory. Seller will not give Buyer credit for parts or equipment returned to Seller, and will not accept delivery of any such parts or equipment, unless Buyer has obtained Seller's approval in writing. The warranty extends to repaired or replaced parts of Seller's manufacture for ninety (90) days or for the remainder of the original warranty period applicable to the equipment or parts being repaired or replaced, whichever is greater. This warranty applies to the repaired or replaced part and is not extended to the product or any other component of the product being repaired. Repair parts of its own manufacture sold after the original warranty period are warranted for a period of one (1) year from shipment against defects in materials and workmanship under normal use and service. This warranty applies to the replacement part only and is not extended to the product or any other component of the product being repaired. Seller may substitute new equipment or improve part(s) of any equipment judged defective without further liability. All repairs or services performed by Seller, which are not covered by this warranty, will be charged in accordance with Seller's standard prices then in effect.

THIS WARRANTY IS THE SOLE WARRANTY OF SELLER AND SELLER HEREBY EXPRESSLY DISCLAIMS AND BUYER WAIVES ALL OTHER WARRANTIES EXPRESSED, IMPLIED IN LAW OR IMPLIED IN FACT, INCLUDING ANY WARRANTIES OF MERCHANTABILITY OR FITNESS FOR A PARTICULAR PURPOSE. Seller's sole obligation under this warranty shall be, at its option, to repair or replace any equipment (or its component parts) which has a defect covered by this warranty, or to refund the purchase price of such equipment or part. Under the terms of this warranty, Seller shall not be liable for (a) consequential, collateral, special or liquidated losses or damages; (b) equipment conditions caused by normal wear and tear, abnormal conditions of use, accident, neglect, or misuse of said equipment; (c) the expense of, and loss or damage caused by, repairs or alterations made by anyone other than the Seller; (d) damage caused by abrasive materials, chemicals, scale deposits, corrosion, lightning, improper voltage, mishandling, or other similar conditions; (e) any loss, damage, or expense relating to or resulting from installation, removal or reinstallation of equipment; (f) any labor costs or charges incurred in repairing or replacing defective equipment or parts, including the cost of reinstalling parts that are repaired or replaced by Seller; (g) any expense of shipment of equipment or repaired or replacement parts; or (h) any other loss, damage or expense of any nature.

The above warranty shall not apply to any equipment which may be separately covered by any alternate or special warranties.

PERFORMANCE: In the absence of Certified Pump Performance Tests, equipment performance is not warranted or guaranteed. Performance curves and other information submitted to Buyer are approximate and no warranty or guarantee shall be deemed to arise as a result of such submittal. All testing shall be done in accordance with Seller's standard policy under Hydraulic Institute procedures.

LIABILITY LIMITATIONS: Under no circumstances shall the Seller have any liability under the Order or otherwise for liquidated damages or for collateral, consequential or special damages or for loss of profits, or for actual losses or for loss of production or progress of construction, regardless of the cause of such damages or losses. In any event, Seller's aggregate total liability under the Order or otherwise shall not exceed the contract price.

ACTS OF GOD: Seller shall in no event be liable for delays in delivery of the equipment or other failures to perform caused by fires, acts of God, strikes, labor difficulties, acts of governmental or military authorities, delays in transportation or procuring materials, or causes of any kind beyond Seller's control.

COMPLIANCE WITH LAW: Seller agrees to comply with all United States laws and regulations applicable to the manufacturing of the subject equipment. Such compliance shall include: The Fair Labor Standards Acts of 1938, as amended; Equal Employment Opportunity clauses of Executive Order 11246, as amended; Occupational Safety and Health Act of 1970 and the standards promulgated thereunder, if applicable. Since compliance with the various Federal, State, and Local laws and regulations concerning occupational health and safety, pollution or local codes are affected by the use, installation and operation of the equipment and other matters over which Seller has no control, Seller assumes no responsibility for compliance with those laws and regulations, whether by way of indemnity, warranty, or otherwise. It is incumbent upon the Buyer to specify equipment which complies with local codes and ordinances.



AURORA®

800 Airport Road
North Aurora, Illinois 60542
630-859-7000
www.aurorapump.com