



FAIRBANKS NIJHUIS™

NOTICE:

You **MUST** have the pump serial number to order the correct parts for your pump.

Record the following information from the motor and pump nameplates for reference when ordering parts or requesting service:

Pump Serial No. _____

Motor Model No. _____

Motor Serial No. _____

H.P. _____ Volts/Hz/Ph _____

Rated Amp Draw _____

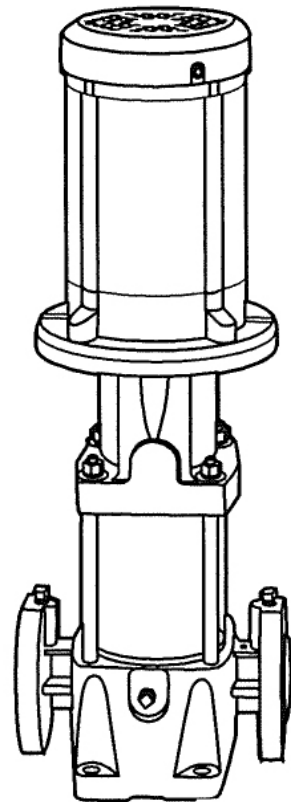

2, 4, 8 and 16 SERIES VERTICAL MULTI-STAGE PUMP STACK KIT

INSTALLATION, OPERATION AND REPAIR PARTS MANUAL

NOTE! To the installer: Please make sure you provide this manual to the owner of the equipment or to the responsible party who maintains the system.

TABLE OF CONTENTS

| | |
|----------------------------|------|
| Safety Instructions..... | 2 |
| Installation..... | 2 |
| Electrical..... | 2 |
| Operation..... | 3 |
| Maintenance..... | 3-6 |
| Troubleshooting Guide..... | 7 |
| Repair Parts..... | 8-11 |

CALIFORNIA PROPOSITION 65 WARNING:

▲ WARNING This product and related accessories contain chemicals known to the State of California to cause cancer, birth defects or other reproductive harm.

Carefully read and follow all safety instructions in this manual or on pump.

▲ This is the safety-alert. When you see this symbol on your pump or in this manual, look for one of the following signal words and be alert to the potential for personal injury.

▲ DANGER warns about hazards that **will** cause serious personal injury, death or major property damage if ignored.

▲ WARNING warns about hazards that **can** cause serious personal injury, death or major property damage if ignored.

▲ CAUTION warns about hazards that **will** or **can** cause minor personal injury or property damage if ignored.

The word **NOTICE** indicates special instructions which are important but not related to hazards.

To avoid serious or fatal personal injury and possible property damage, carefully read and follow the safety instructions.

1. Install pump according to all code requirements.
2. Compare pump nameplate data with desired operating range.
3. Pump only liquids compatible with pump component materials (that is, liquids that will not attack the pump).
4. Make sure plumbing is adequate to handle system pressure.
5. Periodically perform maintenance inspection on pump and system components.
6. Wear safety glasses at all times when working on pumps.

▲ WARNING Hazardous voltage. Voltage can shock, burn, or cause death. Ground pump motor correctly before connecting to power supply, per article 250-80 of the National Electrical Code (NEC) in the U.S., or the Canadian Electrical Code (CEC), as applicable.

INSPECT THE SHIPMENT

The vertical multistage centrifugal inline pump has been carefully inspected and packaged to assure safe delivery. Inspect the pump and fittings and report to the carrier any items which are damaged or missing.

INSTALLATION

Piping

▲ WARNING Explosion and burn hazard. Do not run pump with discharge valve closed; the water in the pump may boil, with risk of explosion and steam burns to anyone near. If there is any danger of the pump running against a closed discharge valve, install a pressure relief or bypass valve in the discharge pipe to allow for minimum liquid flow through the pump. Minimum liquid flow through the pump is needed for cooling and lubrication of the pump (See Table IV). Run the bypass/relief valve and discharge pipe to a floor drain or a tank for collection.

Suction pipe should be adequately sized (See Table V) and run as straight and as short as possible to keep friction losses to a minimum. Pipes, valves, and fittings must have a pressure rating equal to or greater than the maximum system pressure.

ELECTRICAL

▲ WARNING Hazardous voltage. Can shock, burn or cause death. All electrical work should be performed by a qualified electrician in accordance with the National Electrical Code and all local codes and regulations. Make sure that the motor voltage, phase, and frequency match the incoming electrical supply. The proper operating voltage and other electrical information can be found on the motor nameplate. These motors are designed to run up to $\pm 10\%$ of the nameplate-rated voltage. The wiring connection diagram can be found on either a plate attached to the motor or on a diagram inside the terminal box cover.

- If voltage variations are greater than $\pm 10\%$ do not operate the pump.
- Incorrect voltage can cause fire or serious damage to the motor and voids warranty.
- Ground the pump motor correctly before connecting it to the power supply.
- Follow the wiring instructions when connecting the motor to the power lines.

Field Wiring

All wiring connections and wiring sizes must meet National Electrical Code and local requirements.

Motor Protection

See the motor nameplate for electrical connection/wiring diagram.

This pump must be used with the proper size and type of motor starter to ensure protection against damage from low voltage, phase failure, current imbalances, and overloads. The overload should be sized to trip at the full-load current rating of the motor.

OPERATION

See pump owner's manual for instructions on priming, checking rotation, startup, and operation.

MAINTENANCE

Motor Replacement

For Key Numbers, refer to the Exploded View, Figure 6, Page 8 for 2m³ and 4m³ CI Models, Figure 7, Page 9 for 8m³ and 16m³ CI Models, Figure 8, Page 10 for 2m³ and 4m³ SS Models, and Figure 9, Page 11 for 8m³ and 16m³ SS Models.

⚠ WARNING **Hazardous voltage.** Disconnect all power to the pump before servicing or working on pump. Make sure that power is locked out and that pump cannot be accidentally started.

1. Disconnect the power to the pump motor.
2. Close the nearest suction and discharge valves.
3. Remove the coupling guards (Key No. 4) by prying them loose with a screw driver.
4. Remove the socket head screws (Key No. 3) and the coupling halves (Key No. 2) from the shaft (Key No. 16A). For additional reference, see Figure 12, Page 10.

NOTICE: Socket head screws are metric. See Table II on Page 6 for specific metric driver sizes.

5. Remove the shaft pin (Key No. 5).
6. Remove the capscrews (Key No. 13), flatwashers (Key No.11), and lockwashers (Key No.12) that hold the motor (Key No. 1) and the motor bracket (Key No. 6) together.
7. Pull the old motor up and off of the motor bracket.
8. Thoroughly clean the surfaces of the mounting flanges on the new motor and the pump end.
9. Install the new motor on the pump with the conduit box in the desired position.
10. Lubricate the capscrews (Key No. 13) with oil.
11. Reinstall the lockwashers, flatwashers, and capscrews that hold the motor and the motor bracket together, then tighten evenly and diagonally. See Table II, Page 6 for torque specifications.
12. Reinstall the shaft pin (Key No. 5) in the shaft.
13. Reinstall the coupling halves (Key No. 2) on the pump and motor shaft. Make sure to engage the shaft pin (Key No. 5).

NOTICE: Be sure coupling surfaces are thoroughly clean prior to assembly.

14. Snug up the socket head screws (Key No. 3) until the coupling begins to bind and then loosen 1/2 turn.

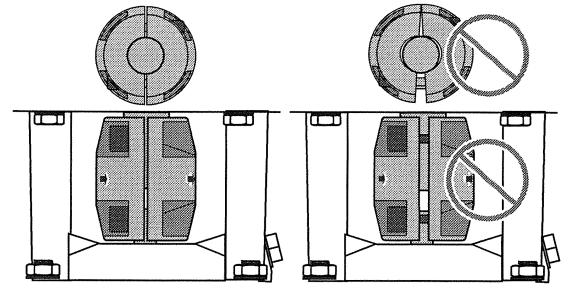

FIGURE 1 - Make Sure that the Coupling Halves are Evenly Tightened

Raise Coupling as far as it will go; then tighten at one-half the height of total axial play.

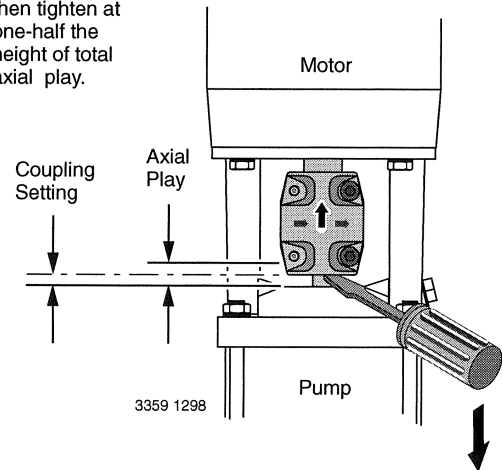

FIGURE 2 - Vertically (axial) Centering the Coupling

15. Draw up the capscrews evenly so the gap between the coupling halves is equal on both sides (See Figure 1).
16. Insert a screw driver under the coupling (See Figure 2).
17. Raise the pump shaft to its highest point.
18. Lower the shaft halfway back down the distance you just raised it and retighten the capscrews. See Figures 1 and 2.

NOTICE: Torque settings are critical to prevent coupling movement. Refer to Table II, Page 6 for torque specifications.

19. Rotate the shaft to make sure that there is no interference. If rubbing is noted repeat steps 16, 17, and 18 above and readjust pump shaft height.
20. Reinstall the coupling guards by snapping them into place.

NOTICE: The guards should be in place before the unit is run.

21. Open the suction and discharge valves. Turn the power back on.

Replacing Pump Stack

▲WARNING **Hazardous pressure.** Do not run pump with discharge valve closed; the water in the pump may boil, causing risk of explosion and steam burns to anyone nearby.

For Key Numbers, refer to the Exploded View, Figure 6, Page 8 for 2m³ and 4m³ CI Models, Figure 7, Page 9 for 8m³ and 16m³ CI Models, Figure 8, Page 10 for 2m³ and 4m³ SS Models, and Figure 9, Page 11 for 8m³ and 16m³ SS Models.

1. Follow steps 1-8 under "Motor Replacement" section on Page 3; then proceed with step 2 below.
2. Remove the four staybolt nuts, flatwashers, and lockwashers (Key Nos. 8, 9A, and 9B) from the staybolts (Key No. 19).

NOTICE: It is not necessary to remove the staybolts when replacing the stack.

3. Lift the motor bracket (Key No. 6) off of the pump body.
- NOTICE:** Note the position of the priming plug. The priming plug must be returned to its original position during reassembly.
4. Remove and discard upper sleeve O-ring (Key No. 17).
5. Clean gasket seat.
6. Remove and replace round spring ring (2m³ and 4m³) or conic spring (8m³ and 16m³) (Key No. 13).
7. Pull the old stack (16A through 16L) out of the stainless steel sleeve (Key No. 18) by pulling straight up on the pump shaft (Key No. 16A).
8. Remove the stainless steel sleeve (Key No. 18).
9. Remove and discard the bottom sleeve O-ring (Key No. 17).

10. Clean the O-ring seat.
11. Remove and discard the O-Ring (Key No. 21A) from the suction/discharge (Key No. 21 2m³ CI and 4m³ CI only).
12. 2m³ and 4m³ Cast Iron Models Only: Clean the O-Ring seat and install a new O-Ring (Key No. 21A).
13. Install a new lower sleeve O-ring.
14. Install the new stack without the stainless steel sleeve.

NOTICE: Be sure to align either the small priming hole or the suction interconnector pin hole (located on the bottom stage of the stack) properly in the base of the Suction/Discharge (Key No. 21). See Figure 11 (not necessary on SS models).

15. Use a rubber mallet to tap the stainless steel sleeve (Key No. 18) into place.
16. Install a new mechanical shaft seal (Key Nos 15A through 15G). Refer to "Mechanical Seal Disassembly and Mechanical Seal Reassembly" sections, Page 5.

17. Install a new upper sleeve O-ring (Key No. 17).
18. Install a new round spring ring or conic spring (Key No. 14).
19. Reinstall the motor bracket (Key No. 6) on the pump body. Align the priming plug (Key No. 10) to its original position.
20. Oil the threads on the staybolts (Key No. 19).
21. Replace the lockwashers, flatwashers, and staybolt nuts (Key Nos. 7, 8 and 9) and cross-torque the staybolts. See Table II, Page 6, for torque specifications.
22. Reinstall the motor (Key No. 1) on the motor bracket (Key No. 6) and turn the motor to the desired terminal box position.

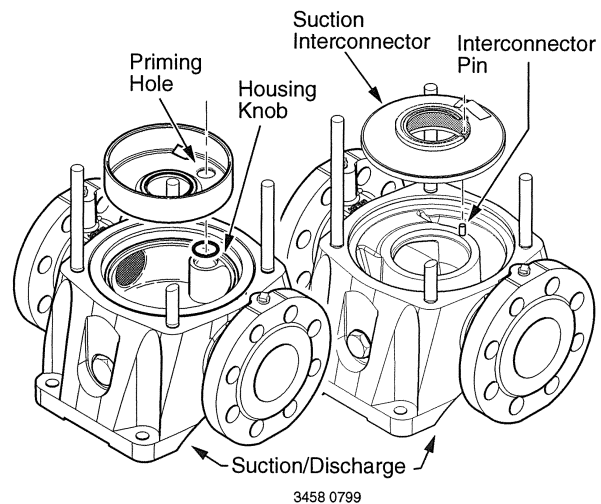

FIGURE 3 - 2m³, 4m³ – Align Small Priming Port. 8m³, 16m³ – Align Interconnector Pin. No alignment is necessary on SS models.

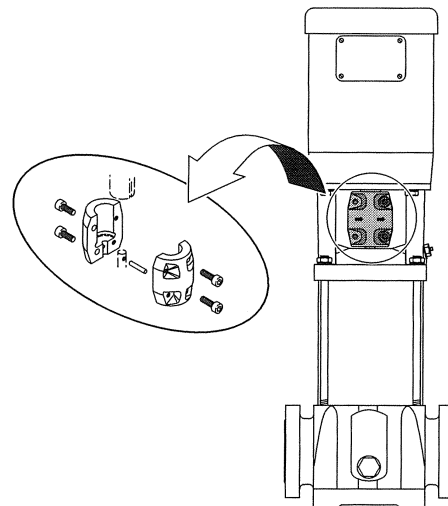

FIGURE 4 - Remove the Socket Head Screws and the Coupling Halves

23. Follow steps 10 - 21 under "Motor Replacement", Page 3. You have now finished changing out the impeller stack.

Seven Part Mechanical Seal/Disassembly:

See Figure 5 for Seal Key Numbers.

See Figures 6 through 9 for Pump Key Numbers.

⚠ WARNING Hazardous voltage. Can Shock, burn or cause death. Disconnect power to pump before disassembly.

1. Follow Steps 1-8 under "Motor Replacement" Page 9, and proceed with step 2 below.
2. Remove the four nuts, lockwashers, and washers (Key Nos. 7, 8, and 9) from the staybolts (Key No. 19).
3. The shaft seal consists of an O-Ring (Key No. 15A), the stationary half of the mechanical seal (Key No. 15B), the rotating half of the mechanical seal (Key No. 15C), a second O-Ring (Key No. 15D - inside No. 15C), a flat washer (Key No. 15E), a spring (Key No. 15F), and a mechanical drive ring (Key No. 15G), in that order, see Figure 13, below. Turn the pump head upside down and remove the stationary part of the seal (Key No. 15B) from the seal seat in the base of the motor bracket.

NOTICE: Use care not to chip or scratch the seal seat during disassembly and assembly.

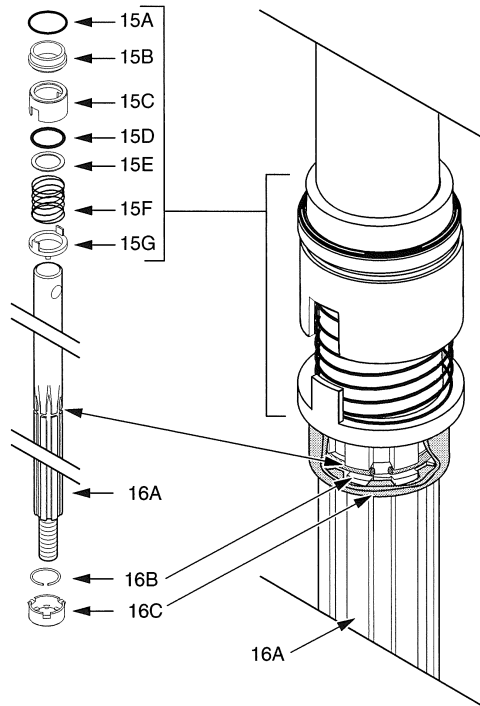

FIGURE 5

4. Clean the seal seat with a wet cloth.
5. Remove the rotating parts of the seal by twisting and pulling up on them until they come off of the shaft (Key Nos. 15C and 15D, 15E, 15F, and 15G). Discard the old seal.

Seven Part Mechanical Seal Reassembly:

NOTICE: Before assembly, check and clean all sealing and gasket surfaces with a clean, wet cloth. Replace all seals, gaskets and O-Rings.

1. Turn the motor bracket (Key No. 6) upside down.
2. Moisten the seal seat (in the motor bracket) with a small amount of water.
3. Lubricate the larger diameter O-Ring (Key No. 15A) with a small amount of water and install it on the stationary half of mechanical seal (Key No. 15B).
4. Press the stationary half of the shaft seal (Key No. 15B) with O-Ring (Key Nos. 15A and 15B) into the seal seat of the motor bracket. Use finger pressure only. If a tool is used, protect the seal face from tools with a clean cloth.

NOTICE: Be sure the seal is installed evenly to avoid pinching the O-Ring.

5. Lubricate smaller diameter O-Ring (Key No. 15D) with water and press it into the rotating half of the mechanical seal (Key No. 15C).
6. Install the mechanical drive ring (Key No. 15G) on the shaft (Key No. 16A). Be sure the drive ring butts up against the mechanical seal spacer (Key No. 16C).
7. Install the spring (Key No. 15F) up against the drive ring on the shaft .
8. Install the flatwasher (Key No. 15E) on the shaft, against the spring.
9. Install the rotating half of the mechanical seal (Key No. 15C) on the shaft. Align the grooves on the rotating half of the mechanical seal with the teeth on the mechanical drive ring (Key No. 15G).
10. Follow Steps 11 - 23 under "Replacing Pump Stack", Page 4.

Frequency of Starts and Stops

Check pump cycling frequency and make sure that the pump is not starting more than:

TABLE I – Maximum Number of Cycles

| Cycles | Motor HP Rating |
|-------------------|-----------------------|
| 20 times per hour | 1/2 - 5 HP motors |
| 15 times per hour | 7- 1/2 - 15 HP motors |
| 10 times per hour | 20 and 25 HP motors |

Frost Protection

1. If you do not use your pump during seasons of frost, drain it and add a glycol based antifreeze (50/50 mixture) to avoid damage.

⚠ CAUTION Risk of water damage and injury. Watch the direction of the priming plug and make sure that liquid escaping from it does not injure persons nearby or damage the motor or other components. In hot water installations, pay particular attention to the risk of injury from scalding hot water.

2. Upon restart, dispose of spent antifreeze properly.
3. Do not replace the drain plug or tighten the priming plug until you put the pump back in service again.

Regular Maintenance Checks

The following checks should be made at regular intervals:

1. The pump meets required performance and is operating smoothly and quietly.
2. There are no leaks.
3. The motor is not overheating.
4. Remove and clean all strainers and filters in the system.
5. Verify amp draw – check motor amperage.
6. Pump wear rings and shaft require no regular maintenance.

TABLE II – Torque Specifications (foot-lbs.) For Cast Iron and Stainless Steel Models

| | Coupling | | | Motor | | Staybolt | | Stack Nut | |
|------------------------------|------------------------------|------------------------------|-------------------------------|-------------------------------------|-------------------------------------|------------------------|------------------------|------------------|-------------------|
| | Socket Head Screw M6 x 20 | Socket Head Screw M8 x 25 | Socket Head Screw M10 x 25 | Capscrew Hex Head 3/8 x 1-1/2 | Capscrew Hex Head 1/2 x 1-1/2 | Hex Nut 1/2 - 13 | Hex Nut 5/8 - 11 | Hex Nut M8 | Hex Nut M12 |
| Hardware Part Numbers | M11369 | M11398 | M11491 | S23568 | S23623 | S26460 | S26462 | M11385 | M11419 |
| Pump Model | | | | | | | | | |
| 2m ³ | 15 | 20 | – | 30 | 35 | 40 | – | 10 | – |
| 4m ³ | 15 | 20 | – | 30 | 35 | 40 | – | 10 | – |
| 8m ³ | 15 | 20 | 45 | 30 | 35 | – | 45 | – | 30 |
| 16m ³ | – | 20 | 45 | – | 35 | – | 45 | – | 30 |

TROUBLESHOOTING GUIDE

⚠ WARNING Hazardous voltage and risk of sudden starts. Disconnect all power to the pump before servicing or working on pump. Make sure that power is locked out and that pump cannot be accidentally started.

| PROBLEM | CAUSE |
|--|--|
| 1. Motor does not run when started | A. Power failure B. Fuses blown C. Motor starter overload has tripped out D. Main contacts in motor starter are not making contact or the coil is faulty E. Control circuit fuses are defective F. Motor is defective |
| 2. Motor starter overload trips out immediately when power supply is switched on | A. One fuse has blown B. Contacts in motor overload relay are faulty C. Cable connections are loose or faulty D. Motor winding is defective E. Pump mechanically blocked F. Overload setting is too low |
| 3. Motor starter overload trips out occasionally | A. Overload setting is too low B. Low voltage at peak times |
| 4. Motor starter has not tripped out but the motor does not run | A. Check 1 A), B), D,) and E) |
| 5. Pump capacity is not constant | A. Pump inlet pressure is too low B. Suction pipe/pump partly blocked C. Pump is sucking air |
| 6. Pump runs but gives no water | A. Suction pipe/pump blocked B. Foot or non-return valve is blocked in closed position C. Leakage in suction pipe D. Air in suction pipe or pump E. Motor rotates in the wrong direction |
| 7. Pump runs backwards when switched off | A. Leakage in suction pipe B. Foot or non-return valve is defective C. Foot valve is blocked in open or partly open position D. Non return valve leaks or is blocked in open or partly open position E. Discharge valve is defective |
| 8. Leakage from shaft seal | A. Pump shaft position is incorrect B. Shaft seal is defective |
| 9. Noise | A. Cavitation is occurring in the pump B. Pump does not rotate freely (That is, there is increased frictional resistance) because of incorrect shaft position |

**2m³ Cast Iron
4m³ Cast Iron**

NOTE: Stack Kit includes Key Nos. 14, 16A through 16L, 17, 21A, 22, and 23. All other parts must be purchased separately.

Serial Number
(necessary for ordering parts.)

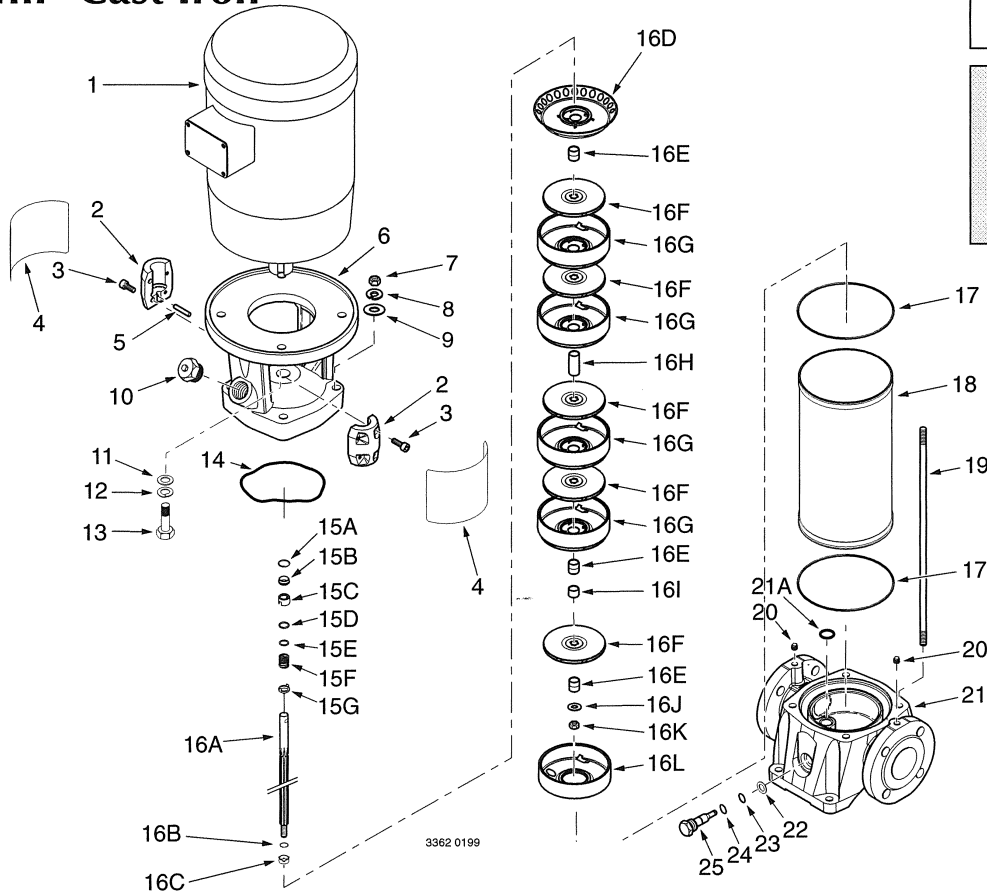
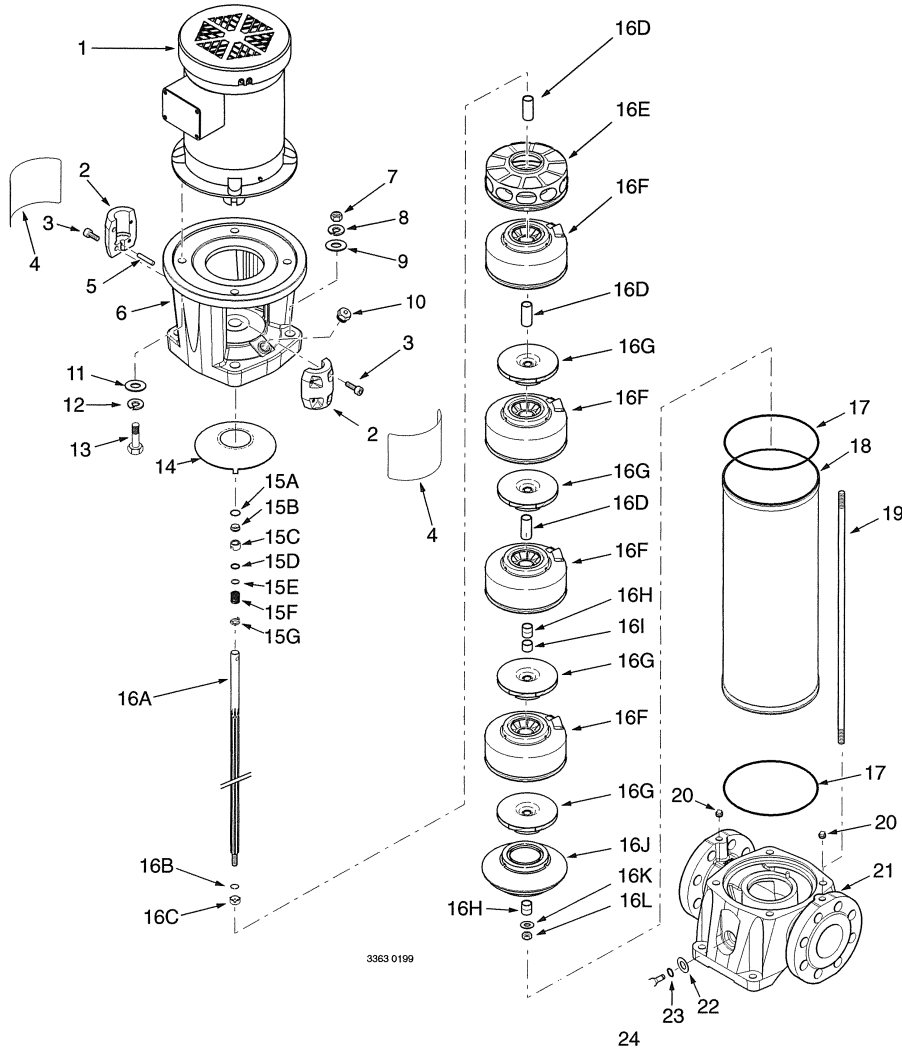

FIGURE 6 - Exploded View 2m³ and 4m³ Cast Iron Models

REPAIR PARTS LIST FOR 2m³ AND 4m³ CAST IRON MODELS

| Key No. | Description | Key No. | Description |
|---------|--|---------|----------------------------|
| 1 | Motor | 16A* | Shaft |
| 2 | Coupling Half | 16B* | Stop Ring |
| 3 | Socket Head Screw | 16C* | Mechanical Seal Spacer |
| 4 | Coupling Guard | 16D* | Upper Intermediate Chamber |
| 5 | Coupling Pin | 16E * | Spacer |
| 6 | Motor Bracket | 16F* | Impeller |
| 7 | Staybolt Nut | 16G* | Diffuser |
| 8 | Staybolt Lockwasher | 16H* | Spacer |
| 9 | Staybolt Flat Washer | 16I* | Bearing |
| 10 | Vented Priming Plug | 16J* | Shaft Washer |
| 11 | Flatwasher | 16K* | Nut |
| 12 | Lockwasher | 16L* | Suction Chamber |
| 13 | Capscrew | 17* | Sleeve O-Ring |
| 14* | Spring Ring | 18 | Stainless Steel Sleeve |
| 15 | Seven Part Mechanical Seal (Includes 15A thru 15G) | 19 | Staybolt |
| 15A | O-Ring, Larger Diameter | 20 | Pipe Plug |
| 15B | Stationary Half of Mechanical Seal | 21 | Suction/Discharge |
| 15C | Rotating Half of Mechanical Seal | 21A* | O-Ring (Bottom Chamber) |
| 15D | O-Ring, Smaller Diameter | 22* | Drain Plug Gasket |
| 15E | Flat Washer | 23* | O-Ring |
| 15F | Spring | 24 | O-Ring |
| 15G | Mechanical Drive Ring | 25 | Drain Plug |

*Included in stack kit. Actual parts included in Stack Kits will vary depending on pump model.



8m³ Cast Iron 16m³ Cast Iron

NOTE: Stack Kit includes Key Nos. 14, 16A through 16L, 17, 21A, 22, and 23. All other parts must be purchased separately.

Serial Number
(necessary for ordering parts.)

Figure 7 - Exploded View 8m³ and 16m³ Cast Iron Models

REPAIR PARTS LIST FOR 8m³ AND 16m³ CAST IRON MODELS

| Key No. | Description | Key No. | Description |
|---------|--|---------|----------------------------|
| 1 | Motor | 16A* | Shaft |
| 2 | Coupling Half | 16B* | Stop Ring |
| 3 | Socket Head Screw | 16C* | Mechanical Seal Spacer |
| 4 | Coupling Guard | 16D* | Upper Intermediate Chamber |
| 5 | Coupling Pin | 16E* | Spacer |
| 6 | Motor Bracket | 16F* | Impeller |
| 7 | Staybolt Nut | 16G* | Diffuser |
| 8 | Staybolt Lockwasher | 16H* | Spacer |
| 9 | Staybolt Flat Washer | 16I* | Bearing |
| 10 | Vented Priming Plug | 16J* | Shaft Washer |
| 11 | Flat Washer | 16K* | Nut |
| 12 | Lock Washer | 16L* | Suction Chamber |
| 13 | Capscrew | 17* | Sleeve O-Ring |
| 14* | Conic Spring | 18 | Stainless Steel Sleeve |
| 15 | Seven Part Mechanical Seal (Includes 15A thru 15G) | 19 | Staybolt |
| 15A | O-Ring, Larger Diameter | 20 | Pipe Plug |
| 15B | Stationary Half of Mechanical Seal | 21 | Suction/Discharge |
| 15C | Rotating Half of Mechanical Seal | 22* | Drain Plug Gasket |
| 15D | O-Ring, Smaller Diameter | 23* | O-Ring |
| 15E | Flat Washer | 24 | Drain Plug |
| 15F | Spring | | |
| 15G | Mechanical Drive Ring | | |

*Included in stack kit. Actual parts included in Stack Kits will vary depending on pump model.

2m³ Stainless Steel
4m³ Stainless Steel

NOTE: Stack Kit includes Key Nos. 14, 16A through 16L, 17 and 22. All other parts must be purchased separately.

Serial Number
(necessary for ordering parts.)

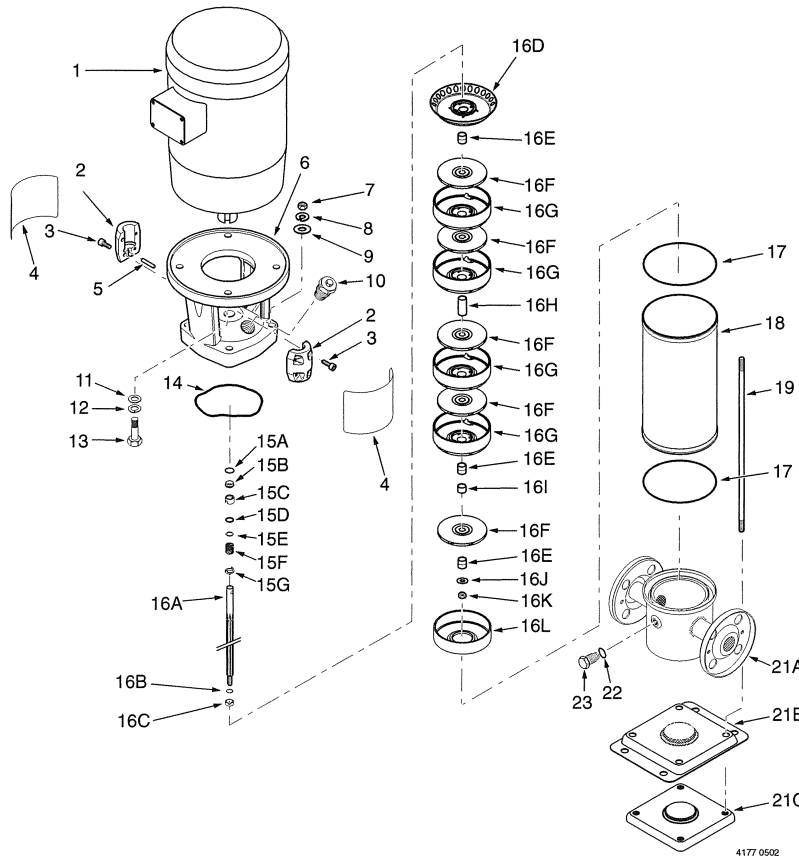
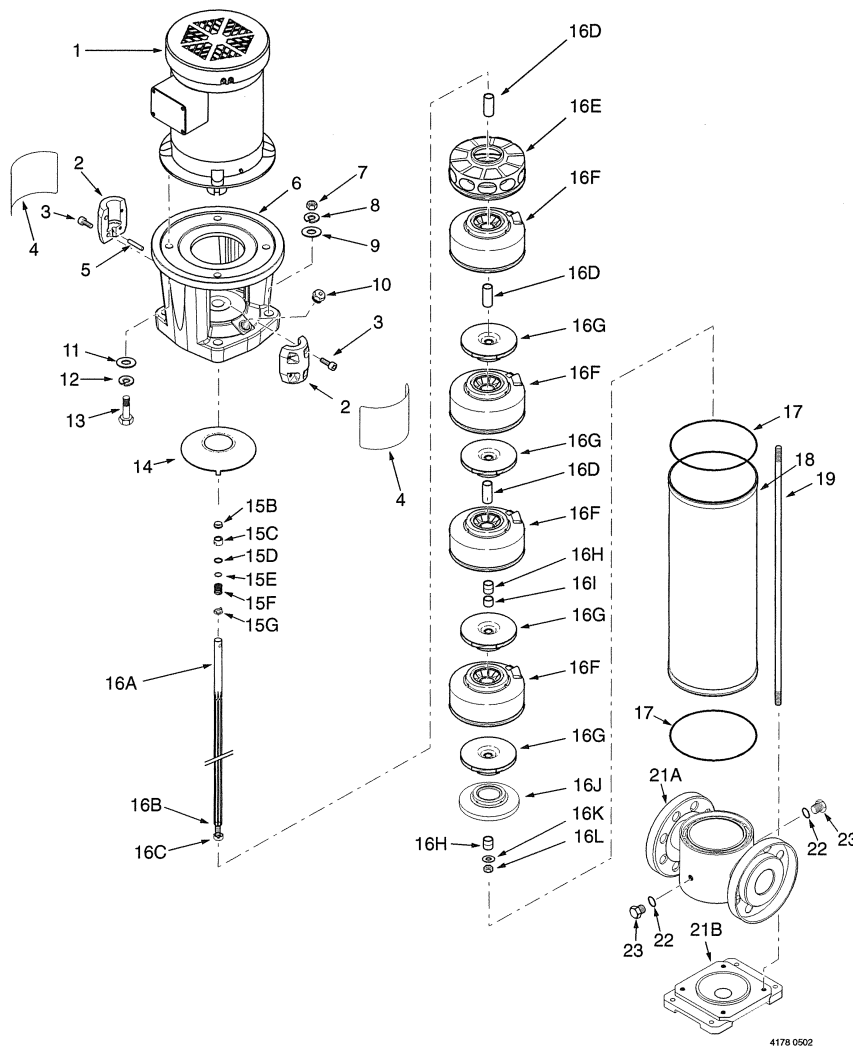

FIGURE 8 - Exploded View 2m³ and 4m³ Stainless Steel Models

REPAIR PARTS LIST FOR 2m³ AND 4m³ STAINLESS STEEL MODELS

| Key No. | Description | Key No. | Description |
|---------|--|---------|----------------------------|
| 1 | Motor | 16A* | Shaft |
| 2 | Coupling Half | 16B* | Stop Ring |
| 3 | Socket Head Screw | 16C* | Mechanical Seal Spacer |
| 4 | Coupling Guard | 16D* | Upper Intermediate Chamber |
| 5 | Coupling Pin | 16E * | Spacer |
| 6 | Motor Bracket | 16F* | Impeller |
| 7 | Staybolt Nut | 16G* | Diffuser |
| 8 | Staybolt Lockwasher | 16H* | Spacer |
| 9 | Staybolt Flat Washer | 16I* | Bearing |
| 10 | Vented Priming Plug | 16J* | Shaft Washer |
| 11 | Flatwasher | 16K* | Nut |
| 12 | Lockwasher | 16L* | Suction Chamber |
| 13 | Capscrew | 17* | Sleeve O-Ring |
| 14* | Spring Ring | 18 | Stainless Steel Sleeve |
| 15 | Seven Part Mechanical Seal (Includes 15A thru 15G) | 19 | Staybolt |
| 15A | O-Ring, Larger Diameter | 21A | Suction/Discharge |
| 15B | Stationary Half of Mechanical Seal | 21B | Base |
| 15C | Rotating Half of Mechanical Seal | 21C | Base Reinforcement |
| 15D | O-Ring, Smaller Diameter | 22* | O-Ring |
| 15E | Flat Washer | 23 | Drain Plug |
| 15F | Spring | | |
| 15G | Mechanical Drive Ring | | |

*Included in stack kit. Actual parts included in Stack Kits will vary depending on pump model.



8m³ Stainless Steel 16m³ Stainless Steel

NOTE: Stack Kit includes Key Nos. 14, 16A through 16L, 17 and 22. All other parts must be purchased separately.

Serial Number
 (necessary for ordering parts.)

Figure 9 - Exploded View 8m³ and 16m³ Stainless Steel Models

REPAIR PARTS LIST FOR 8m³ AND 16m³ STAINLESS STEEL MODELS

| Key No. | Description | Key No. | Description |
|---------|--|---------|------------------------|
| 1 | Motor | 16A* | Shaft |
| 2 | Coupling Half | 16B* | Stop Ring |
| 3 | Socket Head Screw | 16C* | Mechanical Seal Spacer |
| 4 | Coupling Guard | 16D* | Spacer |
| 5 | Coupling Pin | 16E* | Top Diffuser |
| 6 | Motor Bracket | 16F* | Diffuser |
| 7 | Staybolt Nut | 16G* | Impeller |
| 8 | Staybolt Lockwasher | 16H* | Spacer |
| 9 | Staybolt Flat Washer | 16I* | Bearing |
| 10 | Vented Priming Plug | 16J* | Suction Interconnector |
| 11 | Flat Washer | 16K* | Washer |
| 12 | Lock Washer | 16L* | Lock Nut |
| 13 | Capscrew | 17* | Sleeve O-Ring |
| 14* | Conic Spring | 18 | Stainless Steel Sleeve |
| 15 | Seven Part Mechanical Seal (Includes 15A thru 15G) | 19 | Staybolt |
| 15A | O-Ring, Larger Diameter | 21A | Suction/Discharge |
| 15B | Stationary Half of Mechanical Seal | 21B | Base |
| 15C | Rotating Half of Mechanical Seal | 22* | O-Ring |
| 15D | O-Ring, Smaller Diameter | 23 | Drain Plug |
| 15E | Flat Washer | | |
| 15F | Spring | | |
| 15G | Mechanical Drive Ring | | |

*Included in stack kit. Actual parts included in Stack Kits will vary depending on pump model.

